

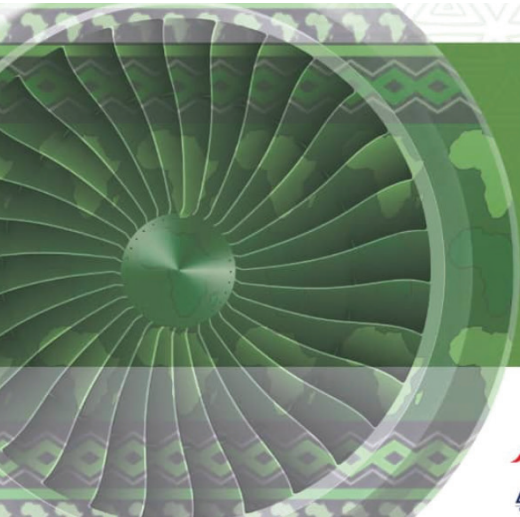

AFRICAN
MRO



**BUILDING AFRICA'S
 SUSTAINABLE
 MRO ECOSYSTEM**

MARCH 29TH - 31ST, 2026



80 Years of Elevating

AFRICAN AVIATION



2026

2036

2046

2056

2066

2076

2086

2096

2106

2016

2006

1996

1986

1976

1966

1956

1946

80 years
1946 - 2026
A TIMELESS LEGACY

ETHIOPIAN
AIRLINES



Ethiopian
የኢትዮጵያ
THE NEW SPIRIT OF AFRICA

STAR ALLIANCE



TABLE OF CONTENTS

Competition Law Guidelines for the AFRAA African MRO Conference	4
Guest of Honour	5
Hosting Airline CEO	5
About the African MRO Conference	10
Conference information	13
Registration	14
Event venues	14
Welcome cocktail	14
Gala dinner	14
Exhibition area floor plan	15
Programme of events	18
Sunday, 29 March 2026	18
Monday, 30 March 2026	18
Tuesday, 31 March 2026	21
Event speakers	24
About sponsors	42
Exhibitors	46



COMPETITION LAW GUIDELINES FOR THE AFRAA AFRICAN MRO CONFERENCE

The African MRO Conference 2026 is a trade association activity of the African Airlines Association (AFRAA). AFRAA is publishing these Competition Law Guidelines to ensure that presentations, discussions and related activities at the African MRO Conference will be conducted in compliance with all applicable competition laws.

STATEMENT OF POLICY

The purpose of the African MRO Conference is to provide a forum for legally permissible discussions of matters and subjects of interest to the aviation industry. It is AFRAA's intent to use the MRO Conference to promote the interests of African aviation, suppliers of aviation products and services, passengers, shippers and the general public and to conduct it in full compliance with the United States antitrust laws, the competition rules of the European Union and the competition laws of all other relevant jurisdictions, taking into account any applicable exemptions or immunities from those competition laws.

PROCEDURAL GUIDELINES

The African MRO Conference shall be conducted pursuant to the following procedures in order to ensure compliance with all relevant competition laws:

1. The African MRO Conference shall be conducted at regular scheduled sessions, at special meetings initiated pursuant to procedures set forth in AFRAA's internal governance rules. All discussions or conversations among MRO Conference participants and attendees, including during breaks and scheduled or non-scheduled social activities connected with the MRO Conference must follow these Guidelines.
2. Sessions of the African MRO Conference shall be conducted in accordance with written programme and agendas that are reviewed in advance by AFRAA counsel familiar with the competition laws of the United States, the European Community and other relevant jurisdictions to assure that the items are in compliance with these laws.

PROHIBITED AGREEMENTS AND ACTIVITIES

1. The following types of agreements, whether express or implied, are STRICTLY PROHIBITED:
 - a. Any collective agreement concerning prices to be charged for services;
 - b. Any collective agreement allocating markets, territories, customers, suppliers or agents;
 - c. Any collective agreement relating to prices to be paid to suppliers, and any other agreement that is intended to, or that in operation is likely to, harm non-participants, including without limitation any agreement that is intended to, or in operation is likely to, exclude nonparticipants from any market; and
 - d. Any agreement that is intended to, or in operation is likely to induce airlines or their suppliers or agents to engage in collective anticompetitive behaviour, or to collectively punish any business enterprise for its exercise of independent business judgment.
2. Recognizing that the existence of an unlawful agreement or concerted practice may be inferred from circumstances, including the exchange of information by competitors, discussions or disclosures of the following types are also PROHIBITED, except when such information has otherwise been made public or AFRAA competition counsel advises that such discussions are legally permissible:
 - a. Individual airline fares, rates, charges or surcharges;
 - b. Individual airline costs;
 - c. An individual airline's intentions regarding increasing, reducing or reallocating aircraft capacity (including entering or exiting routes);
 - d. Information on individual airline customers; and
 - e. Any other sensitive commercial or proprietary information that the company would not disclose in the absence of an express or implied agreement to exchange such information for the purpose of reducing or restricting competition in the airline industry.

GUEST OF HONOUR



Mr. Alume Sime Feyisa
Minister of Transport & Logistics
Republic of Ethiopia

HOSTING AIRLINE CEO



Mesfin Tasew
Chief Executive Officer
Ethiopian Airlines Group



Abdérahmane Berthé
Secretary General
AFRAA



ABOUT THE AFRICAN AIRLINES ASSOCIATION

Founded in 1968 in Accra – Ghana, AFRAA has been instrumental in developing and articulating air transport policy issues in Africa and helping to build a formidable industry.

VISION:

A sustainable, interconnected and affordable Air Transport industry in Africa where African airlines become key players and drivers to African economic development.

MISSION:

To promote, serve African airlines and champion Africa's aviation industry.

OBJECTIVES:

AFRAA as an association has the following strategic objectives:

- i. Safe, secure and reliable air transport
 - Promote the industry best practices to support safe, secure and reliable air transport in Africa.
- ii. Enhance the visibility, reputation and influence of African airlines in the global aviation industry.
- iii. Sustainable air transport
 - Advocate for the reduction of costs of air transport services in Africa by reducing taxes, fees and charges;
 - Strive for the implementation of cost effective Human Resource Development;
 - Lobby for market access to increase revenues and enhance connectivity for the aviation sector in Africa.
- iv. Cooperation
 - Undertake the implementation of joint initiatives aimed at reducing operating costs for airlines, increase revenues and market share.
- v. Data intelligence
 - Become a hub for data, intelligence and expertise on the African Aviation Industry.



AFRAA MEMBERSHIP

Comprises of all the major intercontinental African operators and the Association's members represent over 85% of total international traffic carried by all African airlines.

JOINT PROJECTS

The Association has set up Task Forces/Steering Committees as the vehicle to reduce airline costs, increase their revenues, address members' common interest and adopt industry best practices. These include:

- Fuel Purchase
- Route Network Coordination and Cargo
- Distribution
- Technical, Operations and Training
- Aero political

HOW TO BECOME A MEMBER OF AFRAA

The main criterion for membership of AFRAA is that an airline shall have its registered office and principal place of business in a State eligible for membership of the African Union.

The potential member will have to complete and submit an application form together with the airline's Certificate of Incorporation, Articles of Association and Air Operators Certificate. The completed application form is processed by the Secretariat and submitted to the next regular meeting of the Executive Committee for review and approval. Currently there are **47** member airlines. All Members pay an annual membership fee.

AFRAA MEMBERS

HOW TO BECOME A PARTNER OF AFRAA

Any company other than an airline that does business with or provides services to the aviation industry may apply to become a Partner of AFRAA. The aim of the Partnership programme is to pool together additional support and resources from industry-related organizations to develop the industry while providing opportunities for the Partners to benefit from a relationship with an efficient, knowledgeable and influential air transport trade association in Africa.

A potential Partner will have to complete and submit an application form which will be submitted by the Secretariat to the next regular meeting of the Executive Committee for review and approval. Currently there are **41** companies enrolled on the partnership programme.



AFRAA PARTNERS

ABOUT THE AFRICAN MRO CONFERENCE

The African Airlines Association (AFRAA) and four leading MRO service providers Egyptian Maintenance & Engineering, Ethiopian MRO, Kenya Airways MRO, and South African Airways Technical are pleased to announce the launch of the African MRO Conference.

The premier annual conference and exhibition is dedicated to advancing Maintenance, Repair, and Overhaul (MRO) services across the African aviation sector. Hosted by Ethiopian Airlines from 29-31 March 2026 at the Skylight Hotel in Addis Ababa, Ethiopia, the event aims to establish an MRO marketplace, a dedicated platform for MRO leaders, engineering and maintenance managers, and industry experts to address strategic challenges, explore emerging technologies, and foster partnerships that enhance Africa's MRO capabilities.

Held under the theme: **“Building Africa’s Sustainable MRO Ecosystem”**, the conference will bring together African air operators, OEMs, vendors, and service providers to tackle critical issues such as supply chain disruptions, workforce development, and rising operational costs. Through high level presentations, B2B meetings, and facility tours hosted by Ethiopian MRO, participants will gain insights into innovative tools and best practices that enhance safety, efficiency, and cost effectiveness.

This event also emphasizes the importance of collaboration among African MROs to increase their regional market share and reduce their dependence on off-continent maintenance services.



EVENT PARTNERS AND SPONSORS

The African Airlines Association would like to thank all partners and sponsors for their continued support and all of you, delegates for attending.

 <p>Aero Supplies Global Experience the power of aviation</p>	 <p>BOEING</p>	 <p>Ethiopian የኢትዮጵያ አየርላይንስ THE NEW SPIRIT OF AFRICA</p> <p>A STAR ALLIANCE MEMBER </p>
 <p>GE Aerospace</p>	 <p>GLOBAL AIRTECH</p>	

ABOUT ETHIOPIA

Often called the **Land of Origins**, Ethiopia is a breathtaking tapestry of ancient history and surreal landscapes. From the jagged peaks of the Simien Mountains – the “**Chess Pieces of God**” – to the colorful, volcanic mystery of the **Danakil Depression**, the country’s geography is as dramatic as it is diverse. It is a place where you can walk through medieval history in the **castles of Gondar** or stand in awe before the 11 rock-hewn churches of **Lalibela**, a **UNESCO** masterpiece carved directly into the earth.

Beyond its monuments, Ethiopia’s soul lies in its people and deep-rooted traditions. In the Omo Valley, you’ll encounter some of the world’s most vibrant and preserved indigenous cultures, while in the bustling capital of Addis Ababa, the scent of roasting coffee – the gift Ethiopia gave the world – fills the air. Whether you are trekking alongside endemic Gelada baboons or exploring ancient island monasteries on **Lake Tana**, the warmth of Ethiopian hospitality ensures a journey that is both profound and unforgettable.

TRAVELLER’S ESSENTIALS

Best Time to Visit: October to March for clear skies and lush, post-rain landscapes.

Entry: Easily accessible via e-Visa, with seamless domestic flight connections to the historic north and cultural south.

Safety: While the main tourist circuit is welcoming, always check current travel advisories for peace of mind.

ELEVATING TECHNOLOGY ACROSS EVERY DECADE



Book | Pay | Check-In Online

Get it on



www.ethiopianairlines.com

Ethiopian
የኢትዮጵያ
THE NEW SPIRIT OF AFRICA

STAR ALLIANCE

ABOUT THE EVENT VENUE – SKYLIGHT HOTEL ADDIS ABABA



The Ethiopian Skylight Hotel is a prominent five-star luxury property in Addis Ababa, recognized as the largest hotel in Ethiopia. Located on Airport Road in the Bole district, it is situated just five minutes from Bole International Airport.

Key Features

Capacity: The hotel features 1,024 modern rooms and suites, it serves as a primary hub for Ethiopian Airlines transit passengers, offering 24-hour free airport shuttle services.

In-Terminal Option: There is a separate Skylight In-Terminal Hotel located within the airport for shorter transits, featuring 97 tranquil rooms.

Dining: The property boasts 19 food and beverage outlets, including specialised restaurants for Ethiopian, Italian, Arabian, and Asian cuisines.

Events: It houses the largest hotel ballroom in Addis Ababa, capable of hosting up to 4,000 guests for conferences, weddings, and galas.

Amenities

Wellness: Comprehensive facilities including a full-service spa, sauna, steam room, and a 24-hour fitness center.

Pools: Both indoor and outdoor swimming pools, as well as a dedicated children's pool.

Leisure: On-site entertainment includes a nightclub, bowling alley, and garden areas.

Connectivity: High-speed free Wi-Fi is available throughout the rooms and public areas.

Location & Contact

Address: Airport Road, Bole District, Addis Ababa, Ethiopia

Phone: +251 11 681 8181

Official Website: <https://www.ethiopianskylighthotel.com/>



CONFERENCE INFORMATION

Color codes for name badges: The following are the color codes of the name badges for the various delegate categories.

Registration Type	Color code
AFRAA Member Airlines/African Airlines/ MRO Steering Committee	Blue
AFRAA Partners/Exhibitors	Green
AFRAA Staff/Hosting Team	Brown
Event Sponsor/Speakers	Purple
African MRO	Dark Blue
Aircraft GSE & Tooling Manufacturer/Aircraft Parts Supplier/ MRO Maintenance System Service Provider/ Non-African MRO/ OEM/ Solutions & Service Providers	Yellow
Airports & Civil Aviation Authorities/ Governments & Industry Associations	Orange
Governments & Industry Associations	Light Orange
Media	Red



NB: For security reasons, all delegates are requested to wear their name badges at all times throughout the conference and social functions of the ASC and Safety Summit.

The dress code for the conference sessions is **business formal**.

1. Registration

Registration shall begin on Sunday, 29 March at 0900hrs to 18h00. The registration will extend to Monday, 30 March from 0730hrs

2. Event venues

The venues for the various MRO activities are as follows:

- **Plenary Room** – Abyssinia Ballroom 1 & 2
- **Exhibition Room** – Abyssinia Ballroom 4& 5
- **Welcome Cocktail** – Abyssinia Ballroom 4 & 5
- **Gala Dinner** – Abyssinia Ballroom 1 & 2
- **B2b Meetings** – Abyssinia 3
- **Tea Break** – Concourse
- **Conference Lunch** – Abyssinia Ballroom
- **Media Room** – Mezzanine
- **Masterclass** – Abyssinia Ballroom 1 & 2
- **Masterclass** – Abyssinia Ballroom 1 & 2
- **Secretariat** – Lake Chamo
- **VIP Room** – Lake Chamo
- **Committee Meetings Room** – Lake Tana

3. Welcome cocktail

All delegates are invited to the Welcome cocktail which will take place on Sunday 29th March from 19:00 to 21:00hrs at **Abyssinia Ballroom**

4. Gala dinner

All delegates are invited to the gala and awards dinner which will take place on Monday 30th March from 19:30 – 22:00 at **Abyssinia Ballroom**

EXHIBITION AREA FLOOR PLAN

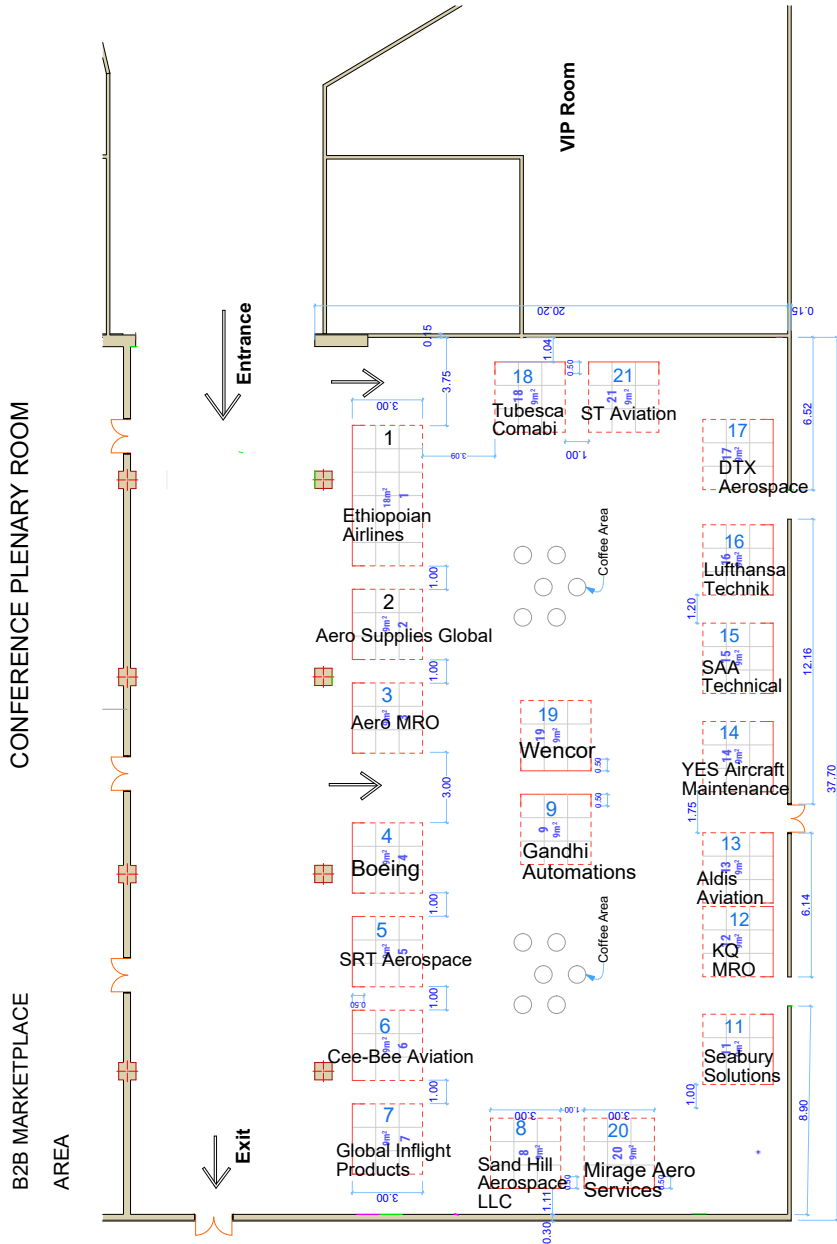

LIST OF EXHIBITORS

Booth No.	Exhibitor	
1	Ethiopian Airlines	
2	Aero – Supplies Limited	
3	Aero MRO	
4	Boeing	
5	SRT Aerospace	
6	Cee-Bee Aviation	
7	Global Inflight Products	
8	Sandhill Llc.	
9	Gandhi Automations Pvt Ltd	
11	Seabury Solutions	
12	Kenya Airways Maintenance	
13	Aldis	
14	YES Aircraft Maintenance	
15	South African Airways Technical	
16	Lufthansa Technics	
17	DTX Aerospace	
18	Tubesca Comabi	
19	Wencor	
20	Mirage Aero Services	
21	ST Aviation	



African MRO 2026 Conference

29 - 31 March 2026

Host: Ethiopian Airlines

Venue: Skylight Hotel, Addis Ababa

Theme: “Building Africa’s Sustainable MRO Ecosystem”

SUNDAY, 29 MARCH

Time	
09:00 – 18:00	<i>Event Registration</i>
09:00- 10 :00	Meeting of the MRO Steering Committee <i>(closed meeting)</i>
10:30 – 12:00	Meeting of the Procurement Subcommittee <i>(closed meeting)</i>
14:00 – 17:30	Maintenance Engineering and Procurement Directors meeting <i>(closed meeting)</i> How operators can better fulfill airworthiness duties through MRO and OEM collaboration while optimizing engineering and maintenance costs.
19:00 – 22:00	<i>Welcome Reception Sponsored</i>

MONDAY, 30 MARCH

Time	
07:30 – 12:00	<i>Registration of participants</i>
09:00 – 09:30	<i>Opening Ceremony</i> <ul style="list-style-type: none"> • Welcome remarks by ET Group CEO, Mr. Mesfin Tasew • Opening remarks by AFRAA Secretary General, Mr. Abdérahmane Berthé • Opening remarks by the MRO Steering Committee Chairman – Mr. Moosa Desai • Opening remarks by Chairman of AFRAA Executive Committee & Ag. CEO Kenya Airways – Capt. George Kamal • Opening remarks by the Minister of Transport and logistics of the Republic of Ethiopia, Mr. Alemu Sime Feyisa
09:30 – 10:20	Panel 1 discussion African MRO landscape and supply chain challenges. A panel session on the current MRO network in Africa and the implications on the airline's bottom line.



	<p>Panelists</p> <ul style="list-style-type: none"> • Mr. Benson Ndirangu Kamau, Head of Technical Materials Management – Kenya Airways • Mr. Santiago Valencia Rodríguez, Head of Maintenance and Supply Chain - ALTA (Latin American and Caribbean Air Transport Association) • Ms. Deborah Acore Luciyamoi, Materials Manager – Uganda Airlines • Mr. Oliver Graef, VP – Sales and Asset Management at Lufthansa Technik Middle East <p>Moderator: Mr. Moosa Desai, Ag. CEO – South African Airways Technical</p>
<p>10:20 – 11:00</p>	<p>Coffee Break & Exhibition Tour - Sponsored by Global Airtech International</p> <p><i>Visit exhibition booths showcasing MRO technologies and training programmes</i></p>
<p>11:00 – 11:50</p>	<p>Panel 2 discussion</p> <p><i>Leadership dialogue: Towards a sustainable African MRO Ecosystem</i> <i>A panel of African MRO leaders on the continent's roadmap to reduce maintenance outsourcing. Will review solutions for African MRO partnerships.</i></p> <p>Panel</p> <ul style="list-style-type: none"> • Eng. Youssef Wahbi, Director of Marketing, Maintenance Contracts, and Customer Support - EgyptAir Maintenance & Engineering • Mr. Daniel Demeke, Managing Director - Ethiopian MRO Services • Mr. Moosa Desai, Ag. CEO – South African Airways Technical • Mr. Vijay Singh MRO Sales and Capability Development Lead - Kenya Airways • Mr. James Ominyi, General Manager, AMO - Aero Contractors MRO <p>Moderator: Mr. Gaoussou Konate, Consulting Director Technical & Operations - AFRAA</p>
<p>11:55 – 12:45</p>	<p>Panel 3 discussion</p> <p>Empowering African Maintenance and Engineering Personnel: Skills, Training, and Retention.</p> <p><i>Focus on human resource development and technical education to see how the continent will fill the gaps.</i></p> <p>Panelists</p> <ul style="list-style-type: none"> • Mr. Laeke Tadesse, President - Ethiopian Aviation University • Mr. Isaac Kivula, Manager Training - Kenya Airways • Mr. Bekele Bayi, Group Vice President, Human Capital Management – Ethiopian Airlines • Mr. Henok Teferra Shawl, Managing Director – Boeing Africa • Mr. Terrance Naidoo, HOD Operations - South African Airways Technical <p>Moderator: Ms. Margareth Kyarwenda, Secretary General - Association of African Aviation Training Organizations (AATO)</p>



12:45 – 14:00	Networking Lunch Sponsored
14:00 – 18:30	B2B meetings Meet technology providers and solution partners. Product and capability demos, as well as face-to-face engagements.
14:00 – 16:00	<p>Masterclasses 2 classes, each 1 hour</p> <p>14:00-15:00</p> <p>Masterclass 1 by LH Consulting: “Modern aircraft engines: challenges & opportunities – a technical and commercial impact analysis.”</p> <p>Despite the reliability of modern aircraft engines, long turnaround times during shop visits disrupt airline commercial operations. What are the causes of these challenges, and how can they be mitigated?</p> <p>Facilitators</p> <ul style="list-style-type: none"> • Dr. Axel Schauenburg, Associate Partner and Solution Group Leader Flight and Technical Operations – Lufthansa Consulting • Mr. Yasser Meddaikar, Management Consultant - Lufthansa Consulting <p>15:00-16:00</p> <p>Masterclass 2 by StandardAero: “Predictive to Profitable: Optimizing Engine Availability and Cost Through Data-Driven MRO Strategies for African Operators.”</p> <p>This masterclass will explore how African operators can leverage predictive maintenance technologies to transition from reactive, schedule-based engine overhauls to condition-based, highly efficient workscopes. StandardAero will present a framework for utilizing Engine Health Monitoring (EHM) data – not just for technical awareness, but for strategic financial planning.</p> <p>The session will address the specific realities of the African landscape, including remote operations and supply chain delays. Participants will learn how data analytics can forecast module life, optimize "time on wing," and reduce unscheduled removals. Crucially, the session will bridge the gap between raw sensor data and actionable business intelligence, demonstrating how to bundle predictive insights with flexible maintenance solutions (like engine exchanges) to maximize fleet dispatch reliability while minimizing cost per flight hour.</p> <p>Key Outcomes for Participants</p> <ul style="list-style-type: none"> • Strategies for converting predictive alerts into optimized, cost-effective shop visit workscopes. • Leveraging engine exchange programs to mitigate AOG risk during remote operations. <p>Facilitator: Mr. Nasser Skalli Housseini, Sales Director – StandardAero</p>
16:00 – 17:00	Networking coffee break Sponsored
19:30 – 22:00	Gala Dinner Sponsored by Ethiopian Airlines Networking evening featuring African cuisine and music



TUESDAY, 31 MARCH

Time	
08:30 – 08:35	Opening Remarks by Programme Director
08:35 – 09:30	<p>Panel 4 discussion How African states can collaborate to facilitate cross-border MRO activities. Focus on certification, mutual certificate recognition. Regulatory bodies and regional safety bodies' cooperation.</p> <p>Panelists</p> <ul style="list-style-type: none"> • Mr. Daniel Demeke, Managing Director - Ethiopian MRO Services • Mr. Laeke Tadesse, President - Ethiopian Aviation University • Mr. James Danga, Safety Expert - African Civil Aviation Commission (AFCAC) • Mr. Santiago Valencia Rodríguez, Head of Maintenance and Supply Chain - ALTA (Latin American and Caribbean Air Transport Association) • Mr. Eric Ntagengerwa, Head of Transport & Mobility Division – African Union Commission <p>Moderator: Dr. Peter Chikumba, Executive Director – Vision Leadership Centre (VLC)</p>
09:30 – 10:30	<p>Panel 5 discussion: Digital Transformation in MRO Global Trends and African Realities. Predictive Maintenance, Big Data, and AI in African Operations.</p> <p>Panelists</p> <ul style="list-style-type: none"> • Mr. Stéphane Colombier, Digital Solutions Marketing Manager – Airbus • Mr. Gobena Uluka, Director Aircraft Engineering and Planning – Ethiopian Airlines • Mr. Sergio Moura, Customer Support and Services Sales Latin America, Europe, Middle East, Asia, and Africa - Embraer • Mr. Luyolo Ndlwana, HOD Commercial - South African Airways Technical <p>Moderator: Mr. Abdérahmane Berthé, Secretary General – AFRAA</p>
10:30 – 11:00	Networking coffee break Sponsored



11:00 – 12:00	<p>Executive Session <i>Green Maintenance – Decarbonizing the African MRO Value Chain. Focus on Global Trends and African Realities. SAF readiness. Recycling. Decarbonization initiatives.</i></p> <p>Presenters</p> <ul style="list-style-type: none"> • Mr. Eric Mulati, Lead - Technical Strategy, Risk & Compliance – Kenya Airways • Mr. Milco Rappuoli, Sales Director Middle East and North East. Africa – ATR • Mr. Raphael Kuuchi, Director Government Legal and Industry Affairs – AFRAA • Mr. Kamil Al-Awadhi. Regional Vice President, Africa and Middle East – IATA <p>Moderator: Mr. Raphael Kuuchi, Director Government Legal and Industry Affairs – AFRAA</p>
12:00 – 12:30	<p>Closing Ceremony</p> <ul style="list-style-type: none"> • Appreciation to Sponsors • Closing remarks by the Host • Date and venue of the next African MRO 2027
12:30 – 14:00	<p>Farewell Lunch Sponsored Press Conference</p>
14:00 – 15:30	<p>B2B meetings <i>Meet technology providers and solution partners. Product and capability demos, as well as face-to-face engagements.</i></p>
15:30 – 18:00	<p>ET MRO facilities visit. <i>Access to be organize in advance.</i></p>
19:30 – 22:00	<p>Coffee/Tea/Drinks Networking</p>



Your Partner in Aviation Materials Excellence

UAE | USA | INDIA | AFRICA

Aero Supplies Global (ASG) is a multinational company with branches located in the UAE, USA, India, and Africa. We provide complete aftermarket solutions to the aviation industry. Through continuous investment and development of stock portfolio of aircraft rotables, tools & equipment, we strive to build an extensive network of global inventory pools, servicing the majority of aircraft types like Airbus, Boeing, Embraer, Bombardier. We are committed to reducing costs while providing first-class support and service to all our customers. We also provide support to Diamond Aircraft, AgustaWestland, Fokker, and Cessna aircraft and other aviation platforms.



COMMITTED TO QUALITY & VALUABLE SERVICE

24x7 AOG SERVICES



OUR PRODUCTS

- Aircraft Tools
- Expendables
- Consumable
- Rotables
- Aircraft Tyres

OUR EXPERTISE

- Inventory
- Sales | Exchange
- Repair & Overhaul
- 3PL Service
- Calibration
- Engine Tooling



PRODUCTS WE DISTRIBUTE

- Aircraft interior carpet cleaning systems and chemicals.
- Aircraft Engine Oil
- Aviation cleaning and surface preparation products.
- Specialty filament products.
- Clean room, wipes, cleaning tools, disinfectant, and decontamination products.
- Aviation hand tools and safety tools.
- Aircraft tires



OUR SERVICES

- ✦ Complete support for Aircraft Consumables, Expendables, Components, Tools & Chemicals.
- ✦ FAA/EASA-certified MRO services
- ✦ FDM & safety software distributed by us
- ✦ Component MRO solutions distributed by us:
 - ✧ Landing Gear Overhaul Boeing Airbus Embraer - CRJ DHC-8- EASA & TCCA Approved
 - ✧ Hydraulic Electrical Harnesses Wide P/N Range
 - ✧ Expert Tech Support
 - SB Eval OEM Implementation DER Harness Solutions

CONTACT US: USA: +1 (786) 818-5049 | UAE: +97165263464 | www.aeroasg.com | sales@aeroasg.com

Follow us on [LinkedIn](#)

EVENT SPEAKERS



Mr. Abdérahmane Berthé
Secretary General – AFRAA

Mr. Berthé was the CEO of Air Mali and Air Burkina. He has 28 years' experience in airline industry and a total of 16 years as an airline CEO. Mr. Berthé built his career in various Airlines and multicultural environment both in Europe and Africa at positions such as aircraft performance and dispatch engineering, maintenance and operations quality, ground operations and Chief Executive Officer. Abdérahmane is graduated from: – French Civil Aviation school in Toulouse (1987 Master of Science degree). – French Aeronautical and Space school in Toulouse (1988 Master of Science degree) – Business Institute in Toulouse (1989 Master degree) He also obtained a Private Pilot License in 1985 for Single Engine Aircrafts.



Mr. Mesfin Tasew
Chief Executive Officer
Ethiopian Airlines
Group

Mr. Mesfin Tasew was appointed as Group Chief Executive Officer of Ethiopian Airlines in March 2022.

He joined Ethiopian in 1984 as Associate Engineer and progressed through the ladder and served in supervisory and managerial positions in the Aircraft Maintenance and Engineering areas. In 1997 and 1999, he was appointed as Director Operations & Technical Systems Support and Chief Information Officer, respectively.

In 2006, he was appointed as Vice President of Maintenance and Engineering.

Mr. Mesfin also served as Chief Operating Officer of Ethiopian Airlines from 2010 – 2021, and Chief Executive Officer of ASKY Airlines from April 2021 to March 2022.

Mr. Mesfin also serves as a member of the International Air Transport Association (IATA) Board of Governors.

He holds BSc and MSc Degrees in Electrical Engineering from Addis Ababa University. He also holds Master's in Business Administration (MBA) from Open University in the UK



Captain George Kamal
Chairman of AFRAA
Executive Committee
& Ag. Chief Executive
Officer
Kenya Airways

Capt. George Kamal is a distinguished aviation executive with 29 years of progressive leadership spanning the Middle East and African aviation markets. Rising through the ranks from frontline operations to the C-suite, Dr. Kamal has successfully led strategic and operational transformation in more than four airlines, delivering sustainable growth, enhanced performance, and industry recognition.

As Chief Operating Officer of Kenya Airways PLC, the national carrier of the Republic of Kenya, he oversees the full operational strategy, performance systems, and regulatory integration for the airline. Under his leadership, the airline continues to align with global aviation standards while advancing safety, efficiency, and service innovation.

Capt. Kamal holds a Doctorate in Business Administration from ESC Clermont School of Business, where he focused on 'Navigating Aviation Industry Economical Evolution and Transformation: Integrating Sustainability, Post pandemic recovery and impact of LCC within African Continent'.

He also earned a Master of Science in Aviation Management – Transformation in the Digital Age from London Metropolitan University, strengthening his expertise in innovation, digitalization, and future-ready aviation systems.

Capt. Kamal was recently voted for & named among the Top 10 Transformational Deputies, MDs, COOs, and VPs of the year 2025 by The Governance & Business Board. The recognition honours his ability to lead with vision, precision, and impact in challenging and complex markets. Known for his disciplined leadership and people-first philosophy, Capt. Kamal drives cross-functional performance, regulatory compliance, and operational excellence across every organization he leads. His current focus includes embedding a performance culture, modernizing core systems, financial restructuring and strengthening regional connectivity. Beyond his executive role, Capt. Kamal is a mentor and industry contributor, advocating for sustainable aviation, future-focused leadership, and strategic collaboration within the global aviation ecosystem.



Mr. Alume Sime Feyisa
 Minister of Transport
 & Logistics
 Republic of Ethiopia

Alemu Sime Feyisa is an Ethiopian professional currently serving as the Minister of Transport and Logistics, a position he has held since January 2023. His leadership in the transport sector is further distinguished by his role as a board member of the United Nations Road Safety Fund (UNRSF), an international appointment he received in March 2025.

Prior to his ministerial tenure, Alemu developed extensive experience in industrial and engineering management. From 2019 until early 2023, he served as the Deputy Director of the Metals and Engineering Corporation (METEC). In addition to his executive roles, he serves as a representative for the Abomsa constituency in the House of Peoples' Representatives, where he contributes to national legislative and policy development.



Moosa Moosa Desai
 Ag. Chief Executive
 Officer
 South African Airways
 Technical

Moosa Desai is a versatile, widely experienced professional with over 30 years of MRO experience. His background spans operations, sales and marketing, engineering, strategy, and business improvement, and he has held various management positions at South African Airways Technical. An aircraft radiotrician by training, he holds an MSc in Business and Strategic Leadership and a BBA in Marketing.



Mr. Daniel Demeke
MD, MRO Services
Ethiopian Airlines

Mr. Daniel Demeke joined Ethiopian Airlines in July 2001 as a Junior Aircraft Technician, after graduating from Ethiopian Aviation Academy. He has been serving in various managerial positions, including Supervisor in Aircraft Maintenance, Manager Scheduled Aircraft Maintenance Hangar, Technical Manager at London Heathrow Airport, and Director Aircraft Base Maintenance.

Currently, Mr. Daniel Demeke is serving as the Managing Director of Ethiopian MRO Services as of October 15, 2024.

He is a graduate of Ethiopian Aviation Academy in Airframe, Powerplant and Avionics Maintenance and type rated on the fleet that Ethiopian Airlines operates. He holds BSC Degree in Electrical Engineering from Addis Ababa University Faculty of Technology, Advanced Diploma in Industrial Chemistry from Bahir Dar University, and Master's in Business Administration (MBA) from Brunel University of London. He has also earned a certificate from London Business school on successful completion of Boeing Leadership Excellence Program.



Henok Teferra Shawl
Managing Director
Boeing Africa

Henok Teferra Shawl is the managing director for Boeing Africa, based in Addis Ababa, Ethiopia.

Teferra Shawl's scope focuses on strengthening Boeing's operations and relationships throughout the African continent. He reports to Dr. Bendan Nelson AO, Senior vice president of The Boeing Company and president of Boeing Global.

Teferra Shawl has over 20 years of public and private sector experience in aviation, diplomacy, and international relations. Before his diplomatic career, Teferra spent over a decade working in the aviation industry, where he held various senior leadership positions at Ethiopian Airlines, including vice president of strategic planning and alliances, vice president of corporate strategy, communications, and director of corporate strategy and government affairs. In another previous role as Chief Executive Officer and board member of ASKY Airlines, Teferra Shawl was responsible for managing the airline's operations, which operates in West and Central Africa.

Additionally, Teferra Shawl was the former ambassador of Ethiopia to France, Spain, Portugal, The Holy See, and Monaco for over three years, where he successfully represented Ethiopia in various diplomatic missions, contributing significantly to the strengthening of Ethiopia's ties with these countries.

Most recently, Teferra Shawl held the position of chief external affairs and regulatory officer at Safaricom Telecommunication Ethiopia (PLC).

Teferra Shawl holds a master's degree in international economic law from the University of Paris I: Panthéon-Sorbonne and a bachelor's degree in international law from the Université Nice Sophia Antipolis.



Mr. Benson Ndirangu Kamau
 Head of Technical Materials Management
 Kenya Airways

Mr. Benson Ndirangu Kamau is a highly experienced aviation professional with over 18 years in aircraft engineering, maintenance planning, simulation, and materials management at Kenya Airways in Nairobi, Kenya. He holds a BSc in Electrical engineering from University of Nairobi and an MSc in Energy Technology from Jomo Kenyatta University of Agriculture and Technology.

As Head of Technical Materials Management since January 2023, he oversees aerospace material provisioning strategy while in compliance with global standards, driving innovation, safety, performance, and supply chain efficiency for the airline's fleet.

His progressive roles at Kenya Airways include:

- Lead Material Planning and Control (2021-2025): Optimized supply chains, inventory, and cross-functional coordination.
- Planning engineering positions (2014-2021): Managed project scheduling, risk mitigation, heavy maintenance layovers, outsourced MRO, cost control, and production systems.
- Simulator Engineer (2010-2014): Maintained CAE 5000 Full Flight Simulators, Moog motion systems, TROPOS visuals, software modifications, and EASA certification processes.

Earlier, he worked in telecommunications industry management at Safaricom and Jamii Telecommunications (2007-2010) .

Passionate about safety, efficiency, and technical excellence, Benson supports Kenya Airways' operational reliability and fleet sustainability in East Africa's aviation sector.



Stéphane Colombier
Marketing Manager
for Digital Solutions
Airbus Commercial
Aircraft

Stéphane Colombier has been the Digital Solutions Marketing Manager for Airbus Services since January 2022. Prior to this role, he worked as a consultant for Maintenance & Engineering within Airbus Customer Support.

Bringing 24 years of operational experience in the aviation industry, Stéphane's expertise spans all Airbus commercial aircraft programs, with a strong background in Part 145 maintenance environments.

His career foundation was built at Aerospatiale Sogerma, where he started in 1998 as an aircraft licensed engineer. He later advanced to a Base Maintenance Manager position for Sabena Technics in Azerbaijan in 2006. In 2009, he transitioned to Airbus Field Service, providing on-site support for airline operations in the United Arab Emirates for entry into service of Airbus A380.

Within Airbus, Stéphane also played key roles in the Airbus Technical AOG Centre (AIRTAC), offering real-time assistance to A380 and A350 operators using the Airbus Real-Time Health Monitoring (AiRTHM) system. Before his current role, from 2018 to 2022, he was part of the Airbus Maintenance & Engineering.

Consulting team, partnering with airlines & MRO to enhance operations and achieve cost efficiencies.

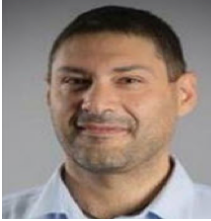

Milco Rappuoli
Sales Director
Middle East and
North East Africa
ATR Aircraft

Born in 1970 in Tuscany (Italy) quickly started to travel the World with the family. An aviation enthusiast since his childhood decided to learn as much of this industry by incremental steps and different angles. The Bachelor at Pisa's university in Aeronautical Engineering has been the first milestone soon followed by the PPL to gather the gut of real flying and finally complemented with an Aerospace MBA at the Toulouse Business School. In 2001 joined ATR as a marketing director in charge of business intelligence and strategic positioning and in 2003 moved to the sales' team in charge – since and to date – of the wider Middle East and North East Africa market.



Mr. Sergio Moura
Services Sales
Manager for Africa
Embraer Commercial
Aviation

Sergio Moura brings over 26 years of experience in commercial aviation, with a strong focus on customer support and services sales across Latin America, Europe, the Middle East, Asia, and Africa. He currently serves as Embraer Services Sales Manager for Africa, working closely with African airlines and MRO partners to support fleet availability, operational reliability, and sustainable maintenance solutions. Sergio holds a degree in Business Administration and an MBA in International Trading and Sales.



Mr. Bekele Bayi Oda
Group Vice President
of Human Capital
Management
Ethiopian Airlines

Mr. Bekele Bayi Oda, the Group Vice President of Human Capital Management at Ethiopian Airlines, is among the strategic architects of human capability who has dedicated his career to the most critical roles of skill acquisition, professional development, and employee retention. Since joining the Group in 2008 as Manager Human Capital Development & Succession Planning, he served on other strategic positions as Manager Placement & Career Development, Manager Human Resource & Finance Ethiopian Cargo & Logistics Service, ADD Hub Ground Services & Ethiopian MRO Services, the three biggest divisions of the Group where employees require intensive training, skill development and retention efforts. His international experience as Traffic & Sales Manager Kano, Nigeria and as Area Manager Switzerland, based in Geneva has provided him not only with a global exposure on how to lead people with diversified background and set of skills, but also enabled him to benchmark best human capital management practices from other global carriers. He has also served as Director Group Personnel Administration right before assuming his current role where he designed employee retention strategy through a comprehensive study whose implementation has significantly improved the human capital management practice of the airline. He has also played remarkable role in establishing strong industrial relation within the Group through systematic leadership and strategic negotiation. By combining his academic background in the areas of Management and Finance with a deep understanding of talent acquisition, development and retention, Mr. Bekele ensures that Ethiopian Airlines does not merely recruit staff but actively cultivates a loyal and highly skilled global workforce capable of sustaining Africa's largest aviation group.



Gaoussou Konate
 Director, Technical
 and Operations
 AFRAA

Mr. Konate joined AFRAA just after he completed a nine-month consultancy contract with the African Development Bank and contributed to the development of the Bank Framework and Guidelines to Support the Aviation Sector in the Region. He brings a vast experience comprising both air transport and civil aviation. His 35-year-corporate experience covered: International Civil Organisation (ICAO), he served as Deputy Regional Director of the Western and Central; for 8 years, he serviced IATA Regional Office for Africa and Indian Ocean (AFI) where he joined as Manager Safety and became Regional Director Safety, Operations, and Infrastructure; as AFRAA Technical Director, he fostered cooperation among African air carriers for 11 years. Before AFRAA, he worked at Air Afrique for just over a decade.



Maureen Kahonge
 Director Commercial
 and Communications
 African Airlines
 Association

Maureen Kahonge is the Director Commercial & Communications at AFRAA, a position she has held since in February 2026. Prior to her appointment, she held the position of Senior Manager Business Development & Communication at the Association. Maureen is a Passionate aviator with 15 years' aviation experience at the African Airlines Association – AFRAA, the leading trade Association of African airlines. She has coordinated various initiatives that facilitate beneficial cooperation among African airlines and with the view to adopt and implement cost-effective common solutions to address market needs. An analytical thinker with commercial orientation and strong customer focus, Maureen is well-versed on air transport industry trends and dynamics. Her role at AFRAA covers the development and management of beneficial working relationships with member airlines and partners, marketing, events, PR & Communications. She is a holder of a Bachelor of Education (Arts) degree in Business Administration and French from Kenyatta University and a Masters in Business Administration Strategic Management and Finance at the United States International University, Kenya. She is a Kenyan in nationality and is fluent in French and English.



Raphael Kuuchi
Consulting Director,
Government, Legal
and Industry Affairs –
AFRAA

Raphael Kuuchi is a Consulting Director for Government, Legal and Industry Affairs at the African Airlines Association (AFRAA). In this role, he leads AFRAA engagements with airlines, governments, regional and industry stakeholders in addressing aero-political and regulatory developments impacting African aviation. He is also involved in the Single African Air Transport Market implementation (SAATM) and airlines environmental and sustainability initiatives in AFRAA.

Prior to his current role, he served for 7 years as IATA Vice President for Africa and subsequently the IATA Special Envoy to Africa on Aero-political Affairs.

Raphael has many years of experience in aviation operations, management, consulting and advocacy. He holds MBA in management and a Business Administration degree in Accounting. He is a Fellow of the Chartered Institute of Logistics and Transport (FCILT) UK.



Eng. Youssef Wahby
Director of Marketing,
Maintenance
Contracts, and
Customer Support
EgyptAir Maintenance
& Engineering

Eng. Youssef Wahby is the Director of Marketing, Maintenance Contracts, and Customer Support at EGYPTAIR Maintenance & Engineering.

With extensive experience in the aviation MRO (Maintenance, Repair, and Overhaul) sector, he leads the company's global outreach, managing technical service agreements for over 140 international customers. Eng. Wahby is a key representative for EGYPTAIR at major industry forums like the International Airlines Technical Pool (IATP) and the Dubai Airshow, where he focuses on building strategic partnerships and expanding the airline's technical footprint across Africa and the Middle East.

Eng. Wahby holds a B.Sc. in Mechanical Engineering (High Honors) from The American University in Cairo (AUC), specializing in Materials & Manufacturing, Design, and Industrial Engineering. He furthered his expertise by earning a Master of Business Administration (MBA) in International Business and Operations Management from Imperial College Business School.



Mr. Vijay Singh
MRO Sales and Capability
Development Lead
Kenya Airways

Vijay Singh is the Lead for MRO Sales and Capability Development at Kenya Airways Engineering & Maintenance, with nearly 20 years of experience in aircraft maintenance and aviation business development. He specializes in driving MRO growth, expanding technical capabilities, and building strategic partnerships across Africa. Vijay is actively involved in advancing Africa's MRO ecosystem and strengthening regional maintenance capacity.



Mr. Laeke Tadesse
President
Ethiopian Aviation
University

Mr. Laeke Tadesse, President of Ethiopian Aviation University (EAU) since April 2025, is a distinguished leader in the aviation sector with extensive experience in airline systems, information technology, and training. His illustrious career began in 1999 at Ethiopian Airlines Group, where he made significant contributions within the Information Technology Division and over the years, he played pivotal roles like Manager of Galileo System Support, Director of Commercial Systems, and eventually Chief Information Officer. Before taking on his current position at EAU, Mr. Laeke served as the CEO of Malawi Airlines, part of an equity partnership with Ethiopian Airlines, where he successfully led the company for four years, guiding the airline to new heights. At EAU, he's focused on transforming the university into a leading aviation training center in Africa. Passionate about competency-based training and industry-integrated curricula, he is dedicated to forging strategic partnerships that will shape the future of aviation professionals. Under his leadership, there's a strong emphasis on hands-on learning, expanding simulators and other aviation training facilities, and strengthening the aviation talent pool across the continent. With deep expertise in airline operations and systems, Mr. Laeke skillfully blends academic education with the practical needs of the aviation industry.



Mr. Isaac Kivula
Manager Training
Kenya Airways

Academic & Professional Background

Educational Qualifications: Diploma in Aeronautical Engineering

Certifications: BI approved Maintenance Engineer,

Career Experience: 32 Years of Aircraft Maintenance Experience

Areas of Expertise / Specialization: Maintenance Instruction on Airframe & Powerplant

Aircraft Type Training Authorization: Authorized Trainer on B777-200/300, B787- 8/9, B737NG, B737CL, Embraer 170/190, B767-200/300.



Ms. Margareth Kyarwenda
Secretary General
Association of African
Aviation Training
Organizations (AATO)

She has a blend of experiences from Air Navigation Services operations, maintenance, project management, and aviation training. Margareth Kyarwenda attained a Full Technician Certificate in Electronics and Telecommunication in 1981. She then graduated with a BSc in Computer Systems & IT and later received a Master of Business Administration. She is a certified aeronautical engineer, ICAO Course Developer, and Instructor. She was also the president of the Tanzania Air Traffic Electronics Safety Association. She actively participated in the establishment of AATO, based in Addis Ababa, Ethiopia, and coordinated the development of the African Aviation Training Roadmap. This training and capacity-building roadmap is a strategic document aimed at outlining the human resource requirements for states to achieve their national objectives and to address performance issues identified through gap analysis. Margareth Kyarwenda is currently serving a second term as the AATO Secretary General.



Dr. Axel Schauenburg
Associate Partner
and Head of Solution
Group Flight and
Technical Operations
Lufthansa Consulting

Dr. Axel Schauenburg is Associate Partner at Lufthansa Consulting based in Frankfurt. He heads the Solution Group Flight and Technical Operations, covering the three work streams Flight Operations, Maintenance & Engineering, and Flight Safety. He has been working in aviation for more than 20 years, focusing on fleet management as well as cost and performance optimization in component, engine, and airframe maintenance.

His experience includes major component programs with airlines, airline groups, and aircraft manufacturers. He holds two aerospace engineering degrees, including a degree in Engineering from the Technical University of Munich, and a Doctorate degree from RMIT University in cooperation with Airbus Helicopters.



Mr. Yasser Meddaikar
Management
Consultant
Lufthansa Consulting

Yasser Meddaikar is a Consultant at Lufthansa Consulting in the Flight & Technical Operations practise, based in Frankfurt. He has substantial expertise in aviation consulting and research. At Lufthansa Consulting, he has worked recently on MRO strategy projects, as well as major transformation projects at Lufthansa Airlines in Germany and in the Middle East region. Prior to this, he has worked at the German Aerospace Center as a research scientist focusing on aircraft design for next-generation civilian applications.



Mr. Gobena Uluka
Director, Aircraft
Engineering &
Planning
Ethiopian Airlines

Gobena Uluka is the Director of Aircraft Engineering and Planning at Ethiopian Airlines, where he spearheads the technical strategy and fleet development for Africa's largest aviation group. With a solid academic foundation in Aeronautical Engineering and advanced training in Aviation Strategic Management, Mr. Uluka has built a distinguished career within the airline's technical divisions. He is instrumental in overseeing the acquisition and maintenance standards of a modern fleet that includes the Boeing 787 Dreamliner and Airbus A350, ensuring the highest levels of safety and operational efficiency. His leadership in Fleet Planning and MRO (Maintenance, Repair, and Overhaul) operations continues to be a driving force behind the airline's rapid global expansion and its reputation for technical excellence.



Mr. Eric Mulati
Technical Strategy,
Risk Compliance
Kenya Airways

Eric Mulati is a global strategy and program leader and aeronautical engineer with over 15 years of experience delivering large-scale transformation, operational strategy, and multi-million-dollar programs across the aviation, technology, and infrastructure sectors. With a strong foundation in aircraft engineering and maintenance operations, he brings deep expertise in airline technical operations, Maintenance, Repair and Overhaul (MRO), and aviation asset lifecycle management. He is recognized for aligning strategy, execution, and governance to deliver sustainable measurable outcomes including revenue growth, cost optimization, and capability development.



Mr. James Danga
Safety Expert
African Civil Aviation
Commission (AFCAC)

James Danga is the Aviation Safety Expert at the African Civil Aviation Commission (AFCAC) based in Dakar, Senegal. He is coordinator of the AFI-CIS Program with extensive experience in airline certification and surveillance. Previous experience includes serving ICAO TCB as Regional Safety Inspector at COSCAP-SADC in Gaborone, Botswana and the Civil Aviation Authority of Zimbabwe as Director Flight Safety & Standards. James has over 26 years of experience in aviation of which 18 years have been at the aviation regulatory/policy level.

He is a licensed aircraft maintenance engineer, ICAO CMA Subject Matter Expert (Airworthiness) and a qualified GSI Instructor – AIRWORTHINESS. He is a holder of several post graduate diplomas in airworthiness and aviation management.



Mr. Oliver Graef
Vice President of Sales, Asset and Account Management
Lufthansa Technik Middle East

Oliver Graef is an accomplished aviation executive with more than 25 years of international experience in sales leadership, asset management, and technical operations. Currently serving as Vice President of Sales, Asset and Account Management at Lufthansa Technik Middle East, he leads regional commercial strategy, customer engagement, and asset optimization across the Middle East, Africa and South Asia from the company's Dubai hub.

Throughout his career with Lufthansa Technik, Oliver has held progressively senior roles across Germany, China, and the Middle East, including Vice President Sales & Account Management, Senior Sales Manager, Product Sales Manager, and multiple project leadership positions. His background uniquely integrates commercial expertise

with deep engineering roots, shaped by earlier roles as a Project Engineer and Technical Draftsman.

Oliver holds an MBA from the University of Salzburg and a Mechanical Engineering qualification from Technikerschule, bringing together strong technical foundations and advanced business leadership. His global mindset, customercentric approach, and proven track record in driving growth continue to make him a key contributor to the aviation services sector.



Dr. Peter Chikumba
Founder and Executive Director
Vision Leadership Centre

Dr. Peter Chikumba has served as Chief Executive Officer of both Air Zimbabwe and Air Namibia, and as Regional Director for Africa at the International Air Transport Association (IATA) where he played a pivotal role in advancing aviation development across the continent.

Today, he is the Founder and Executive Director of Vision Leadership Centre, where he focuses on leadership development and strategic advisory across Africa.

He is currently leading transformative initiatives to establish internationally certified Maintenance, Repair and Overhaul (MRO) and Approved Training Organisation(ATO) facilities, aligned with global standards, with a bold vision to position Africa as a self-sustaining aviation hub.



Santiago Valencia
 Director of
 Maintenance and
 Supply Chain
 Latin American
 and Caribbean Air
 Transport Association
 (ALTA)

Santiago Valencia is the Director of Maintenance and Supply Chain at ALTA – the Latin American and Caribbean Air Transport Association, where he leads regional airline committees focused on maintenance, MRO and technical procurement. He is also Chairman of the ALTA CCMA & MRO Conference, the leading MRO and technical supply chain event in Latin America and the Caribbean, and a frequent contributor to industry forums on MRO strategy and supplier collaboration.



Luyolo Ndlwana
 HOD Commercial
 South African Airways
 Technical

Luyolo Ndlwana is the Commercial Director for South African Airways (SAA), where he leads strategic initiatives to bolster the airline's regional and international competitiveness. A vocal advocate for the liberalization of African skies, he focuses on lowering travel costs and enhancing connectivity across the continent through integrated planning and network optimization. His leadership is central to SAA's operational recovery, emphasizing "collaboration, collaboration, collaboration" as he manages critical partnerships in Maintenance, Repair, and Overhaul (MRO) and negotiates strategic codeshare agreements. Ndlwana also oversees the airline's transition toward fleet modernization, moving away from secondhand aircraft to more efficient new fleets to ensure long-term commercial sustainability.

Reconnecting ATLANTA

STARTING FROM MAY 21, 2026

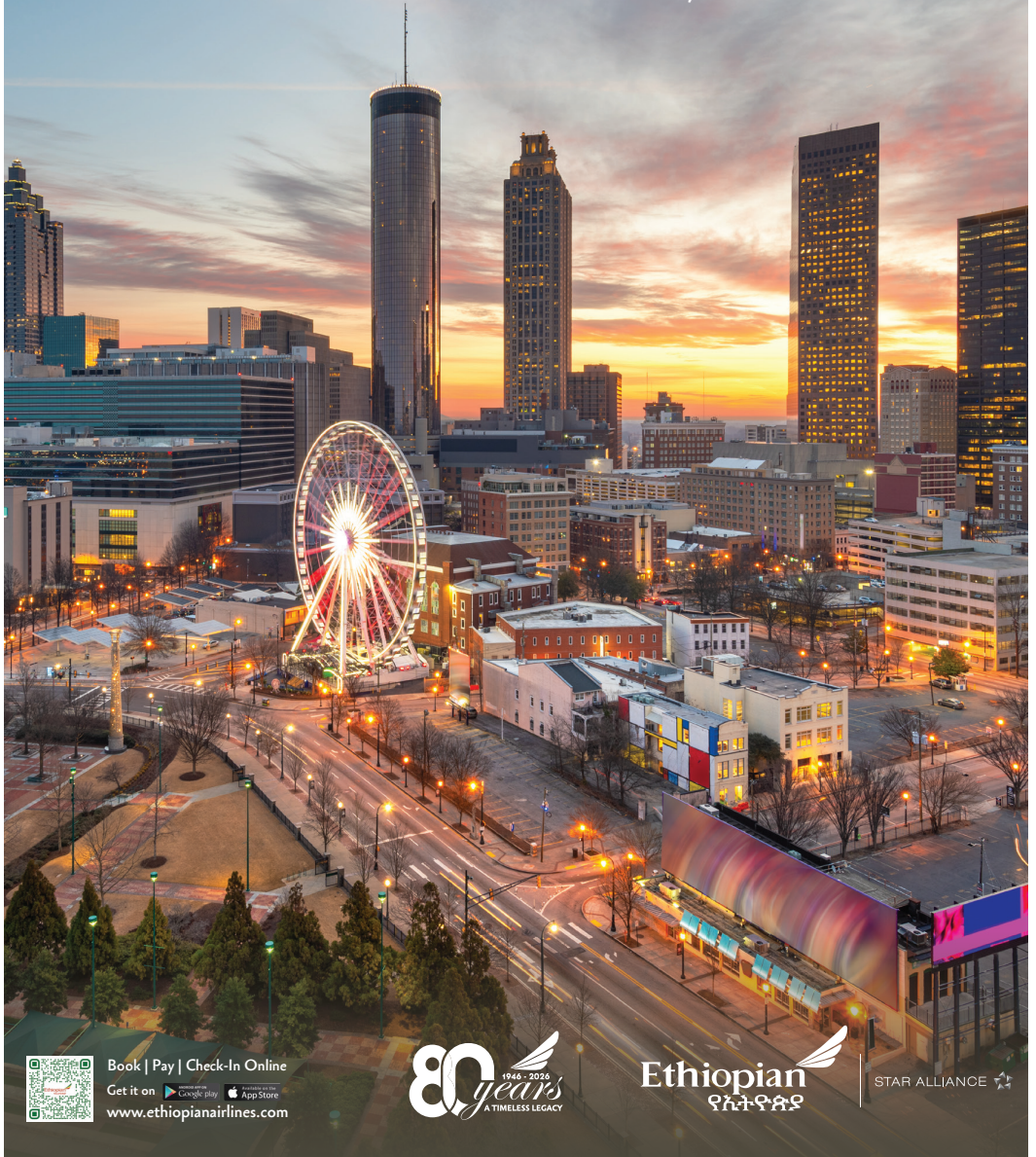

Book | Pay | Check-In Online

Get it on  Google Play  App Store

www.ethiopianairlines.com

80 years
1946 - 2026
A TIMELESS LEGACY

Ethiopian
የኢትዮጵያ

STAR ALLIANCE 



ABOUT SPONSORS



Aero Supplies Global (ASG) is a multinational company with branches located in the UAE, USA, India, and Rwanda. We provide complete aftermarket solutions to the aviation industry. Through continuous investment and development of stock portfolio of aircraft rotables, tools & equipment, we strive to build an extensive network of global inventory pools, servicing the majority of aircraft types like Airbus, Boeing, Embraer, Bombardier. Committed to reducing cost and providing first class support and service to the customer. We also provide support to Diamond Aircraft, AgustaWestland, Fokker, and Cessna aircraft, etc

AERO SUPPLIES GLOBAL DWC
G01, Ground Floor, Supplier Complex
DWC-Mohammed Bin Rashid Aerospace Hub, Dubai, United Arab Emirates
www.aeroasg.com | +971 65263464
Mail: sales@aeroasg.com

AERO SUPPLIES GLOBAL LLC
3105 NW 107TH AVE STE 400 DORAL, FL 33172 , United States
www.aeroasg.com | +1 (786) 818-5063
Mail: usasales@aeroasg.com
Warehouse Address - 5881 SW 21st St, West Park, FL 33023, United States



As a leading global aerospace company, Boeing develops, manufactures and services commercial airplanes, defense products and space systems for customers in more than 150 countries. As a top U.S. exporter, the company leverages the talents of a global supplier base to advance economic opportunity, sustainability and community impact. Boeing's diverse team is committed to innovating for the future and living the company's core values of safety, quality and integrity.

Boeing's heritage in Africa dates back over 75 years, with more than 60 airline customers operating around 500 Boeing airplanes. Currently, Boeing has an office in Johannesburg, South Africa, in addition to field service representatives with commercial customers across the continent.

Learn more at www.boeing.com

Boeing Corporate Offices
100 North Riverside
Chicago, Illinois 60606
Main switchboard: 312-544-2000
Investor Relations: 312-544-2140



A STAR ALLIANCE MEMBER 

Founded on December 21, 1945, Ethiopian Airlines Group has evolved from a five-aircraft operation into Africa's leading aviation powerhouse and one of the fastest-growing airline brands globally. Under the leadership of Group CEO Mr. Mesfin Tasew and guided by the ambitious Vision 2035 roadmap, the 100% government-owned Group operates an ultra-modern fleet of 168 aircraft – including the pioneering Airbus A350-1000 and Boeing 787 Dreamliner – serving over 145 international destinations. Beyond its primary hub at Addis Ababa's Bole International Airport, the Group pursues a strategic multi-hub model across Togo, Malawi, Zambia, and the DRC, supported by an integrated ecosystem that includes the continent's largest MRO facility, a million-ton capacity cargo terminal, and the ICAO-recognized Ethiopian Aviation University. With a commitment to the "New Spirit of Africa," the Group's Code of Conduct emphasizes operational excellence, safety, and authentic hospitality, ranging from its award-winning "Cloud Nine" service to the world-class Skylight Hotel, ensuring Ethiopian remains a dependable, award-winning link between Africa and the world.



GE Aerospace

GE Aerospace is a global provider of aircraft engines, systems, and services, with revenues exceeding \$30 billion. As a leader in aviation technology, GE Aerospace continues to design, develop, and manufacture jet engines, components and integrated systems for commercial, military and general aviation aircraft as well as aero-derivative gas turbines for marine applications. In addition, GE Aerospace is the world's leading integrated engine maintenance resource.

For more information, contact:

Alison Dekkers

RGM Africa

Alison.dekkers@ge.com

Mobile: +31 6 11 17 65 59



Global Airtech is a U.S.-based aviation spare parts distributor specializing in inventory-backed AOG support and structured component solutions for commercial airlines and MRO facilities worldwide. With warehouse operations in Los Angeles, Miami and Singapore, with 24/7 AOG coverage, the company supports Boeing and Airbus operators, including B737, B777, A320 Family, and A330 platforms.

Certified to ASA-100 and AS9120 standards, Global Airtech supplies fully traceable components with FAA 8130-3 documentation. Core services include exchange and loan programs, engine and APU support, heavy check material supply, repair management, and credit terms for qualified operators.

As a B2B Session Sponsor, Global Airtech is focused on building long-term supply partnerships with African airlines and MROs seeking reliable, compliant, and inventory-backed spares support.



Aviation Asset Specialists

Founded 1989 - 24/7 AOG Support - Inventory Solutions

WHAT WE DO



Critical Support

24/7 Comprehensive No-Go Item and MEL Solutions to Support Your Fleet

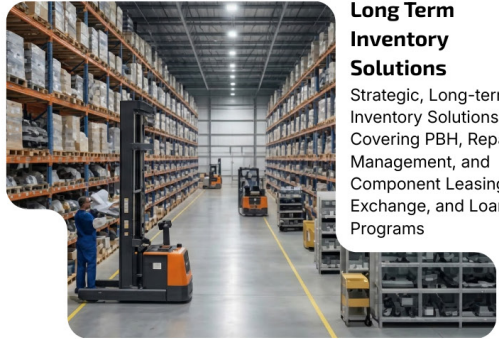

Long Term Inventory Solutions

Strategic, Long-term Inventory Solutions Covering PBH, Repair Management, and Component Leasing, Exchange, and Loan Programs



HOW WE DO IT

CUSTOMER CENTRICITY

Delivering first-class support by building trusted relationships grounded in quality, value, and complete customer satisfaction

QUALITY COMMITMENT

Global Airtech is committed to meeting customer, statutory, and regulatory requirements, while continuously enhancing customer satisfaction through ongoing improvement of our products, services, and quality management system.

COST LEADERSHIP

Unconstrained by in-house facilities, we leverage our extensive ecosystem of OEM and MRO partners to optimise costs and strengthen the supply chain.

IN-REGION PARTNER

Through our regional presence in people and inventory, we remain close, responsive, and connected to our customers.

THE HUMAN IMPACT

BEYOND COMPONENTS

We protect your operations and reliability so you can deliver a seamless passenger experience



CONNECT WITH US

✉ sales@globalairtech.com,
aogdesk@globalairtech.com

🌐 **Website:**
www.globalairtech.com

📞 **Phone:**
+1.888.996.2588

🌐 **LinkedIn:**
www.linkedin.com/company/global-airtech





EXHIBITORS



Consulting

Our areas of expertise

Airline Restructuring | Technical & Operations | Training
Safety Finance | Commercial | Aviation Policy | Master Plans

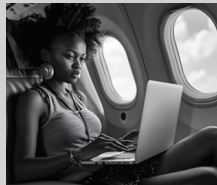

- Cost effective consulting services;
- Tailored solutions from experts who understand the African context;
- High quality deliverables;
- Contribution to improve air transport sustainability in Africa.

Contact us: African Airlines Association (AFRAA)

PO Box 20116, Nairobi 00200 - Kenya

Email: consulting@afraa.org | **Tel:** +254 20 23 20 144 / 23 20 148

Office Mobile: +254 722 209708 | **Website:** www.afraa.org



14TH AVIATION STAKEHOLDERS CONVENTION



17 - 19 MAY 2024 - JOHANNESBURG, SOUTH AFRICA



SOUTH AFRICAN AIRWAYS
A STAR ALLIANCE MEMBER

To register contact us: African Airlines Association (AFRAA)
P O Box 20116 Nairobi 00200 - Kenya
Email: afraa@afraa.org | **Tel:** +254 20 23 20 144 / 23 20 148
Office Mobile: +254 722 209708 | **Website:** www.afraa.org